

## COVID-19 modelling update: Considerations for a potential fourth wave

17 Nov 2021

### Summary:

- **This report focuses on projections of hospital admissions as the primary outcome.** The numbers of infections and detected cases may be comparable to earlier waves, depending on the scenario; however, the ratio of admissions and deaths to infections and cases is expected to be substantially lower than in previous waves, as a result of the vaccination coverage, particularly among the elderly, and protection from prior exposure.
- Model scenarios depict admission waves of different sizes in each of the provinces as a result of changes in behaviour, which reflects a combination of government-imposed restrictions and individual actions.
- Even in the hypothetical scenario of a complete abandonment of a behavioural response to resurgence, the **size of the 4th wave in admissions is projected to be smaller than the 3rd wave, in the absence of a new variant.**
- If a variant with a 25% relative reduction in protection from prior infection and vaccination enters circulation, the **resultant wave in admissions is expected to be higher** (compared to the no variant scenarios), though vaccines will continue to have an impact and may protect the most vulnerable from severe illness.
- **If increases in contacts occur in January, as opposed to November, later and smaller waves are expected** as a larger proportion of the population will be vaccinated.
- It is important to note that smaller peaks in admissions do not necessarily imply that future waves will have less impact on the health system and health care workers. **Whether or not the admissions will result in overwhelmed hospitals and avoidable COVID-19 deaths also depends on how much hospital capacity can continue to be made available.**
- Even with continued behavioural fatigue, **rapid vaccination** of the population provides a powerful tool to reduce severe illness and death.

### Purpose

The purpose of this report is to provide updated scenario projections of the timing and size of a potential fourth wave of COVID-19 cases in South Africa, taking into account the progress of the SARS CoV-2 vaccination programme so far, and estimating the impact of changes in public health and social

measures (PHSM), population behaviour, and a hypothetical new variant of concern (VOC). We aim both to inform the public and to provide planning support, in particular to the National and Provincial Departments of Health and National Treasury.

## **Caveats**

Due to the rapidly changing nature of the epidemic globally and in South Africa, our projections are updated regularly as new data become available and should be interpreted with caution. Changes in testing policy and hospitalisation criteria will impact the number of cases detected as well as the number of hospital admissions and deaths that can be positively identified as associated with COVID-19. In addition, saturation of hospital capacity, particularly during surges, could result in lower reported admissions (and potentially, in higher numbers of deaths) than currently projected.

This version of the National COVID-19 Epi Model (NCEM v6.0) is a provincial-level model. District or sub-district level heterogeneity within provinces could result in longer, flatter provincial waves than projected, and small-scale localised cluster outbreaks are not captured by the model. Visit [www.SACMCEpidemicExplorer.co.za](http://www.SACMCEpidemicExplorer.co.za) for regularly updated data regarding cases and admissions in all provinces, districts, and sub-districts in the country.

Please direct all questions concerning this report to Dr Harry Moultrie, National Institute for Communicable Diseases ([harrym@nicd.ac.za](mailto:harrym@nicd.ac.za)).

## **1. Factors influencing the shape and timing of the fourth wave**

The updated model continues to incorporate the impact of behaviour change, in particular reduced adherence to non-pharmaceutical interventions (now termed public health and social measures, PHSM), and the response to increasing mortality. The model has been updated to take into account the impact of the ongoing COVID-19 vaccination roll-out as well as, in a subset of scenarios, simulate the impact of a hypothetical new variant of concern (VOC). It has also been fitted to updated data regarding the seroprevalence of SARS-CoV-2 antibodies by province and age group, the distribution of variants in circulation, hospital admissions, confirmed COVID-19 deaths, and excess mortality.

### ***Impact of seroprevalence at the end of the third wave***

A large number of studies have estimated the seroprevalence of SARS-CoV-2, a measure of previous exposure to the virus, in various settings and populations in South Africa between July 2020 and August 2021. These studies covered locales in all provinces, but none were representative across provinces or the South African national age profile. The number of seroprevalence studies varies considerably across provinces, with few estimates available for Limpopo, the Free State, and the Eastern and Northern Cape, resulting in higher uncertainty for these provinces.

Figure 1 shows the seroprevalence estimates used to calibrate the model by province (Figure 1A) and age group (Figure 1B). A clear upward trend is discernible, with most estimates from June or July 2021 arriving at values of 50% to 60% seroprevalence. Preliminary estimates from studies conducted as part of the PHIRST-C community cohort study around the end of the third wave, are particularly high, being between 59% (Mpumalanga site) and 69% (North West site).

Figure 1: Model calibration to seroprevalence data by (A) province and (B) age group.

(A)

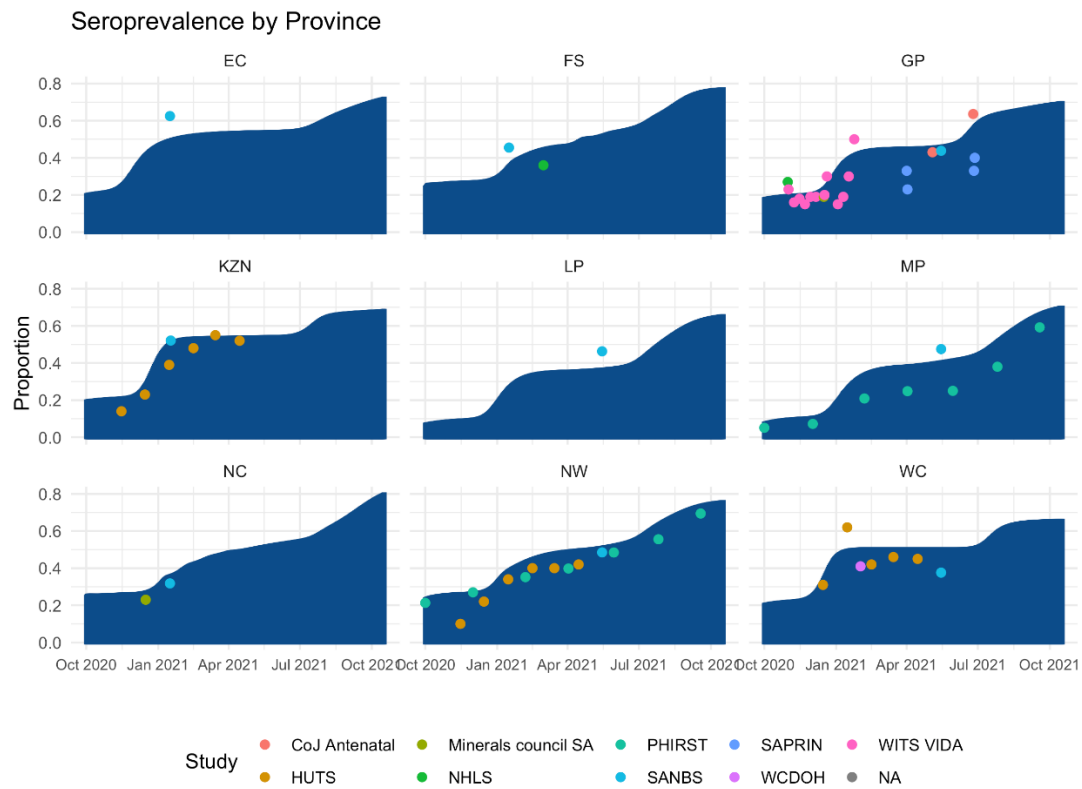

(B)

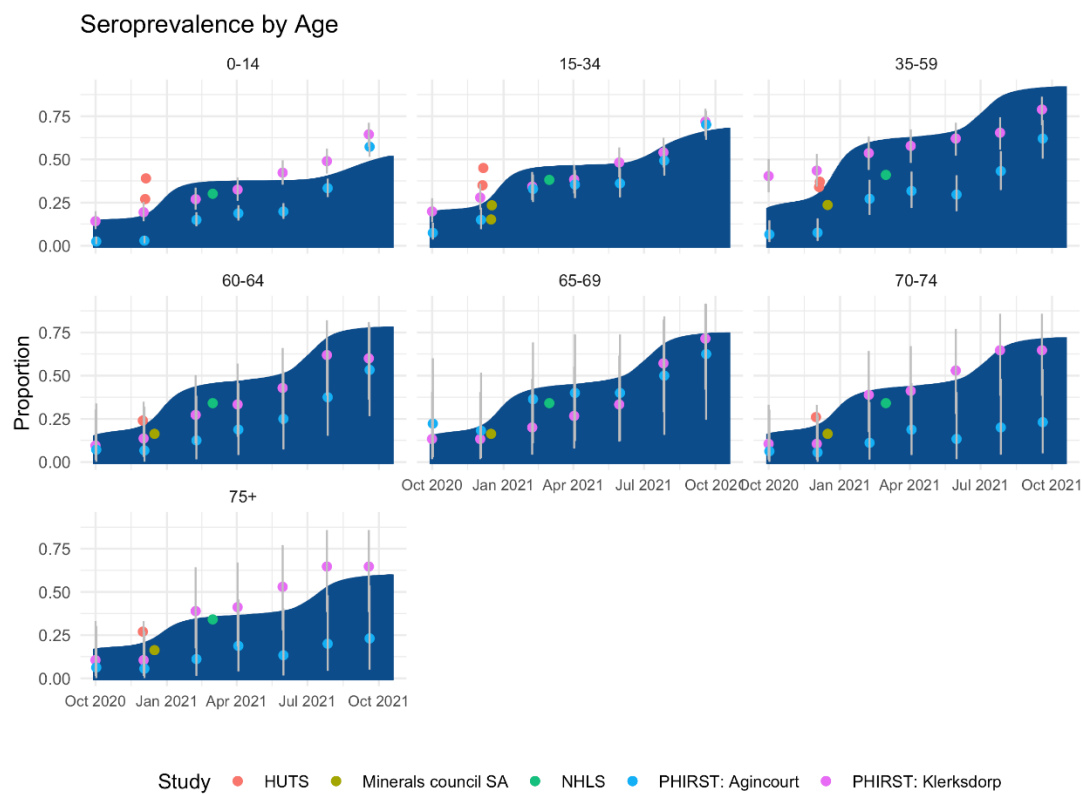

## **Impact of vaccination**

Vaccination against COVID-19 reduces both a vaccinee's risk of developing severe and critical COVID-19 and the risk of infection, though the latter effect wanes to lower levels within 3 months post-vaccination<sup>1,2,3</sup>. The model takes into account the pace of the vaccine roll-out, and the coverage across age groups, provinces, and vaccine types it has achieved so far, based on real-time data from the Electronic Vaccine Data System (Figure 2).

**Figure 2: EVDs data on vaccines administered by day and province**

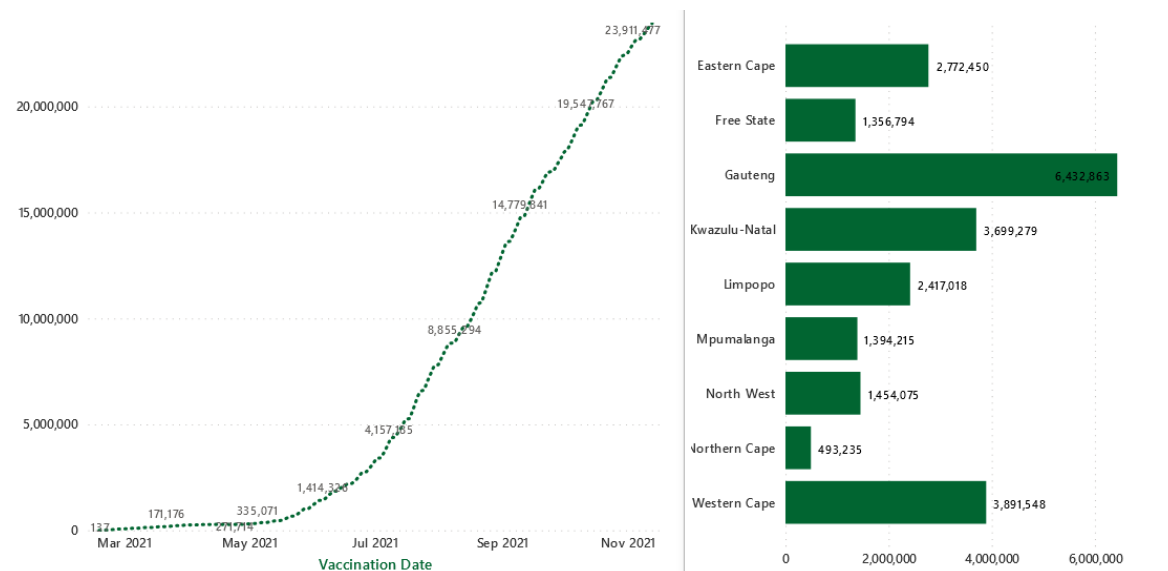

Source: <https://sacoronavirus.co.za/latest-vaccine-statistics/>. Accessed 14 Nov 2021

Forward projections incorporate the impact of the ongoing vaccine roll-out, assuming a vaccination rate that achieves vaccine coverage of 70% of adults vaccinated with at least 1 dose of J&J or Pfizer by 31 March 2021. The simulated roll-out achieves 75% coverage in the above 60 year olds and slightly lower coverage in younger age-groups to reach 70% coverage overall. We did not include the most recent policy update (i.e., offering a single dose of Pfizer to 12-17 year olds).

In terms of vaccine effectiveness, we incorporated vaccine efficacy estimates against infection and severe illness based on data from clinical trials and large observational studies for the Pfizer and J&J vaccines against the Delta variant<sup>1,4,5</sup>. Our estimates of vaccine effectiveness were applied equally across age groups, in absence of reliable age-stratified data. Additionally, we assumed that vaccine protection against infection wanes to zero over 6 months for the population not previously infected with SARS-CoV-2, while vaccine protection against hospitalisation and death does not wane during the projection window in the absence of a new variant.

<sup>1</sup> Andrews, et al. (2021) Vaccine effectiveness and duration of protection of Comirnaty, Vaxzevria and Spikevax against mild and severe COVID-19 in the UK. <https://www.medrxiv.org/content/10.1101/2021.09.15.21263583v1>

<sup>2</sup> Tartof, et al (2021) Effectiveness of mRNA BNT162b2 COVID-19 vaccine up to 6 months in a large integrated health system in the USA: a retrospective cohort study. [https://doi.org/10.1016/S0140-6736\(21\)02183-8](https://doi.org/10.1016/S0140-6736(21)02183-8)

<sup>3</sup> Goldberg, et al (2021) Waning Immunity after the BNT162b2 Vaccine in Israel. <https://www.nejm.org/doi/full/10.1056/NEJMoa2114228>

<sup>4</sup> Pouwels et al. Effect of Delta variant on viral burden and vaccine effectiveness against new SARS-CoV-2 infections in the UK. <https://www.nature.com/articles/s41591-021-01548-7>

<sup>5</sup> Gray & Bekker (2021). Update on the Janssen (JNJ) Ad26.COVID.S vaccine. <https://sacoronavirus.co.za/wp-content/uploads/2021/08/Sisonke-Provisional-Results-6-August-2021GG2.pdf>

### **Impact of behaviour change**

Behaviour change, as it pertains to the rate of potentially infectious contacts between individuals, continues to be one of the main drivers of the timing and peak of the fourth wave. Factors that influence contact rates include holiday travel, large events such as religious and political gatherings, changes in adherence to PHSM such as mask wearing, and changes to government-imposed restriction levels. The projections presented here focus on the impact of behaviour change, acknowledging substantial uncertainty in the timing and the rate of change in both nationally-directed and individual behaviour, in particular with regard to reduced PHSM adherence due to fatigue. We show the results of three main scenarios that characterise the responses to resurgence as a composite measure of government decisions regarding PHSM, including restrictions and other policies as part of the risk-adjusted strategy levels, as well as individual adoption of PHSM. We parameterise these changes in behaviour as an increase or decrease in the province-specific behavioural response threshold (BRT), expressed as the number of deaths that trigger a population behavioural response that reduces potentially infectious contacts. This report includes the following scenarios:

- A. Same BRT that was estimated during wave 3, where no further PHSM fatigue or increase in contact rates occurs in the coming months
- B. 2x BRT in A (similar to the most extreme behavioural scenario in the third wave modelling reports<sup>6,7</sup>), where further PHSM fatigue and increases in contact rates occur in the coming months
- C. No BRT (ie, no reductions in contacts in response to mortality at all), representing a scenario of a complete abandonment of PHSM measures

Note that scenarios A and C are not intended to be realistic, credible representations of future behaviour, but are selected to demonstrate extreme situations to understand the variability of model outputs.

### **Simulating the impact of a hypothetical new variant on concern with relevant immune escape**

It is important to note at the outset that it is not possible to predict the timing of emergence or the likely characteristics of new variants of concern (VOC). In considering the characteristics of potential VOC to include in the scenarios, we reviewed several modelling studies exploring the potential impact of new VOC, but based our assumptions of the hypothetical variant on a 3-model study from the UK<sup>8</sup>. In light of the already high transmissibility of Delta, the estimated seroprevalence in South Africa, and the ongoing vaccination roll-out, we chose to include a hypothetical immune escape variant without increased transmissibility. We simulated one set of scenarios incorporating the emergence of an immune escape variant with 25% relative reduction in protection against infection conveyed through prior infection and vaccination, with partial loss of protection against hospitalisation.

### **Difficulties in fitting models for the Northern Cape and Free State**

The Northern Cape and Free State provinces had atypical trajectories in previous waves with sustained periods of high transmission. These atypical trajectories were likely the result of a combination of

---

<sup>6</sup> SACMC: COVID-19 modelling update: Considerations for a potential third wave. Report, 29 April 2021.

<sup>7</sup> SACMC: COVID-19 modelling update: Considerations for the third wave, including the impact of the Delta variant of concern. Report, 14 July 2021.

<sup>8</sup> Dyson L, Hill EM, Moore S, Curran-Sebastian J, Tildesley MJ, Lythgoe KA, House T, Pellis L, Keeling MJ: Possible future waves of SARS-CoV-2 infection generated by variants of concern with a range of characteristics. *Nature Comm* 12,5730 (2021)

spatial characteristics, timing of VOC introductions with superimposed Beta and Delta waves, and local behavioural responses. Furthermore, there are very limited seroprevalence data available for these two provinces, which substantially increases uncertainty. Fitting models to these unusual trajectories is challenging and results in considerable uncertainty and instability of projections. While we have elected to show the projections for these two provinces despite the additional uncertainty in the data for these provinces, projections for the Northern Cape and Free State should be treated with substantial caution.

## 2. Model scenarios

Taking into account behavioural response and immune escape variant, we have created the following four scenarios, not all of which are equally probable. In order to represent the uncertainty with regards to timing of these changes, we present two sets of projections across all scenarios: One where we assume that changes in behaviour and introduction of an immune escape variant occur simultaneously in November 2021, and one where we assume that both will happen only in January 2022.

**Table 1: Summary of model scenarios**

	<b>Behavioural response threshold (BRT) triggered by total deaths</b>	<b>Proportional efficacy of prior infection and vaccination</b>
<b>1</b>	2x	No immune escape variant
<b>2</b>	No BRT	No immune escape variant
<b>3</b>	1	0.75
<b>4</b>	2x	0.75

## 3. Simulating a potential fourth wave

### ***Scenario 1: Behavioural response threshold increased (2x), no immune escape variant***

If behaviour had changed (increases in contacts) in early November 2021, in the absence of a new variant the model projects an increase in hospital admissions in the coming months in all provinces apart from the Northern Cape - though this increase is projected to be considerably smaller than seen in previous waves (Figure 3A). The absence of a resurgence in the Northern Cape is the result of the higher estimated seroprevalence in the province and the province-specific behavioural response threshold used to fit the model to prior waves. If behaviour change occurred later, from January 2022, the peak in admissions would be later but of a similar size. Importantly, however, across provinces the higher vaccination rates among the population aged 60+ years reduces projected severe cases and admissions in this population to low levels (Figure 3B). On the other hand, admissions in the youngest age group (0-14 years) are projected to reach levels close to wave 3.

**Figure 3A: Fourth wave scenario 1: Impact on hospital admissions, by province (compared to 2<sup>nd</sup> and 3<sup>rd</sup> waves).** Orange bars represent admissions data from the DATCOV hospital surveillance database of the National Institute of Communicable Diseases (NICD); blue curves represent model fits/projections.

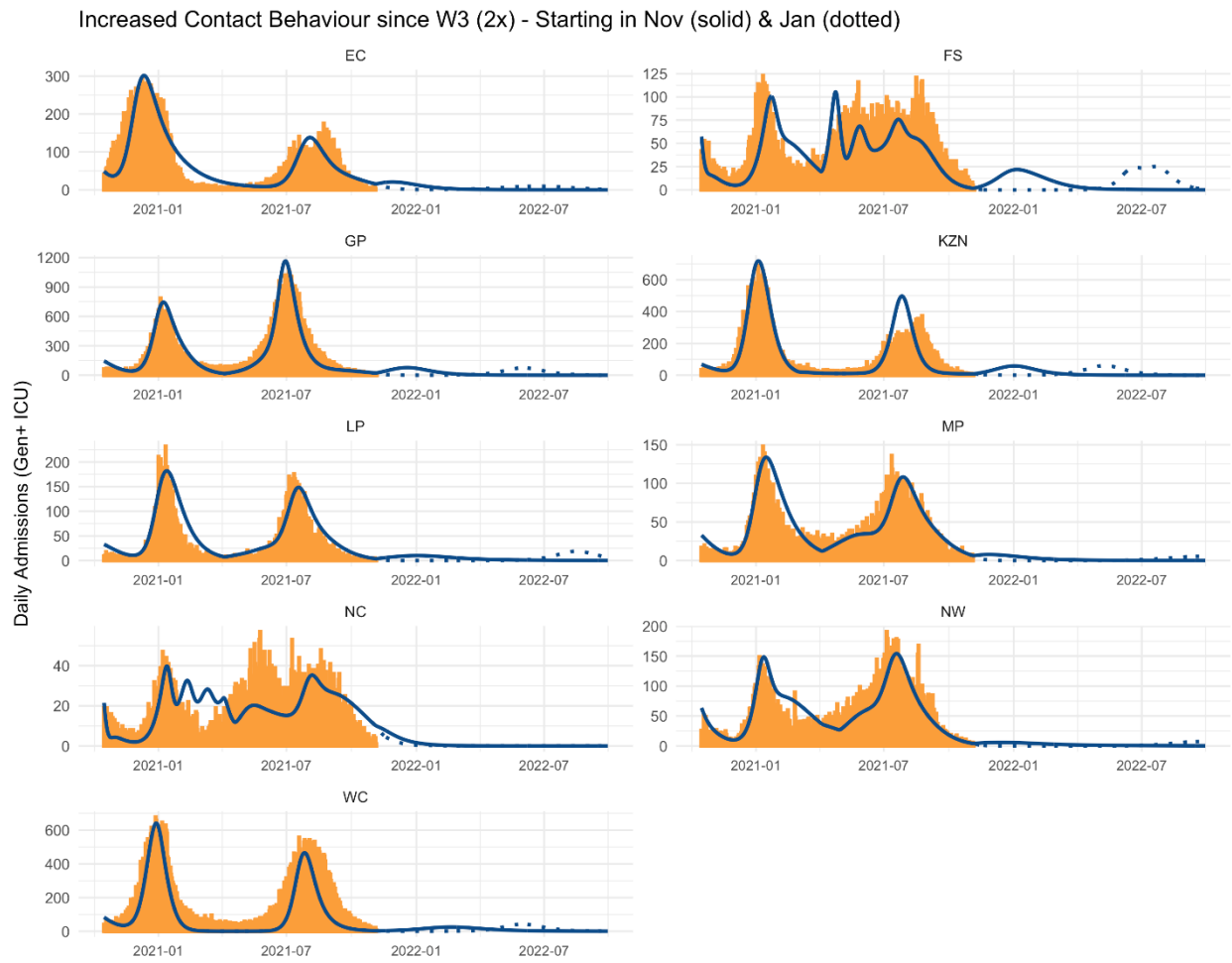

**Figure 3B: Fourth wave scenario 1: Impact on hospital admissions, by age group (compared to 2<sup>nd</sup> and 3<sup>rd</sup> waves).** Orange bars represent admissions data from DATCOV/NICD; blue curves represent model fits/projections.

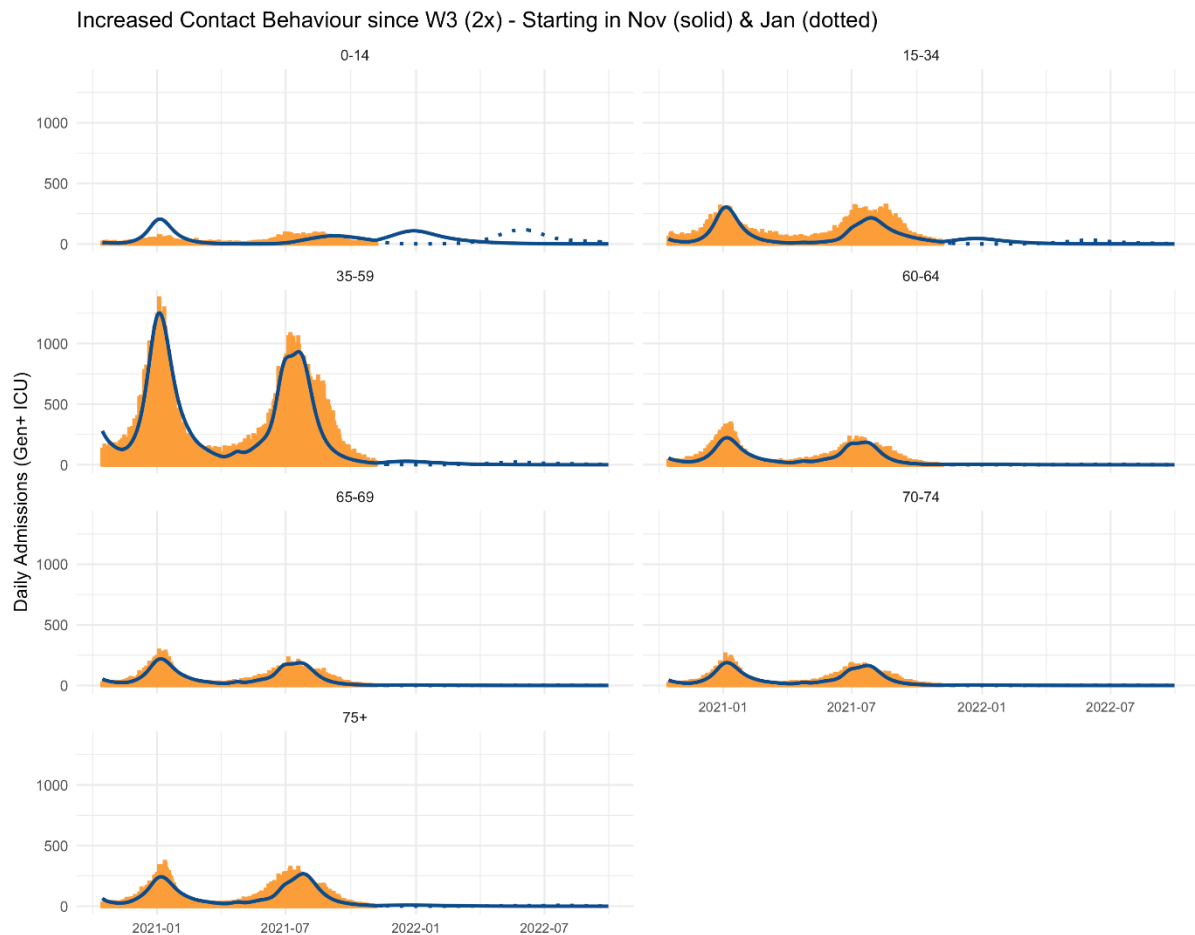

**Scenario 2: Behavioural response threshold removed, no immune escape variant**

In this hypothetical, extreme scenario, in which we assume no population-level response to an increase in deaths, peak hospital admissions across provinces are higher than in scenario 1 but still generally lower than observed during the second wave, and lower than the third wave in almost all provinces with the exception of the Eastern Cape (Figure 4). As in scenario 1, a delayed onset of behaviour change further reduces the peak admissions during the fourth wave. This scenario is extreme and hypothetical because it represents a complete abandonment of protective measures in response to rising deaths (and cases). However, the scenario has value in that it provides an upper bound for the impact of behaviour change alone in the coming months.



**Figure 4: Fourth wave scenario 2: Impact on hospital admissions, by province (compared to 2<sup>nd</sup> and 3<sup>rd</sup> waves).** Orange bars represent admissions data from DATCOV/NICD; blue curves represent model fits/projections. Note that this scenario is considered unrealistic but provides a bound for comparison.

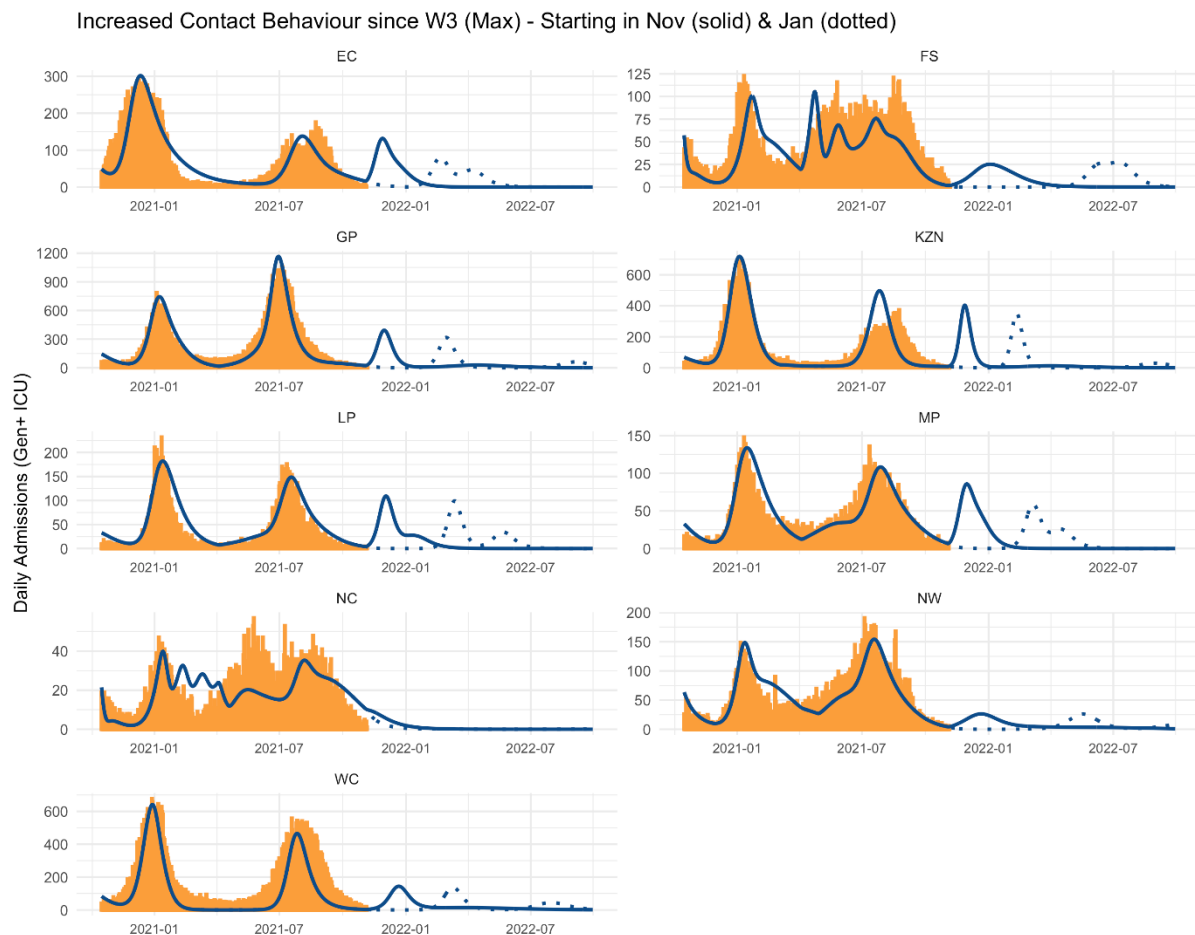

**Scenario 3: No change in behaviour after third wave, immune escape variant present**

In this scenario, the model projects the impact of a new VOC with relevant immune escape properties (expressed as 25% relative reduction in protection from prior-infection and vaccination) without behaviour change (i.e., no increase in contact rates). Slow, limited increases in hospital admissions are projected across all provinces, with the exception of the Northern Cape, where an atypical trajectory throughout the previous waves results in a greater effect of the hypothetical new variant (Figure 5). Note that this scenario is not a realistic one as it is unlikely that contact behaviour will remain constant through the December holiday period. With established patterns of internal migration, school closures, and public holidays, population movement and contacts are expected to increase. The value of presenting this scenario is to demonstrate the spread and impact of the immune escape variant on its own, without increasing contacts to increase incidence.

**Figure 5: Fourth wave scenario 3: Impact on hospital admissions, by province (compared to 2<sup>nd</sup> and 3<sup>rd</sup> waves).** Orange bars represent admissions data from DATCOV/NICD; blue curves represent model fits/projections. Note that this scenario is considered unrealistic but provides a bound for comparison.

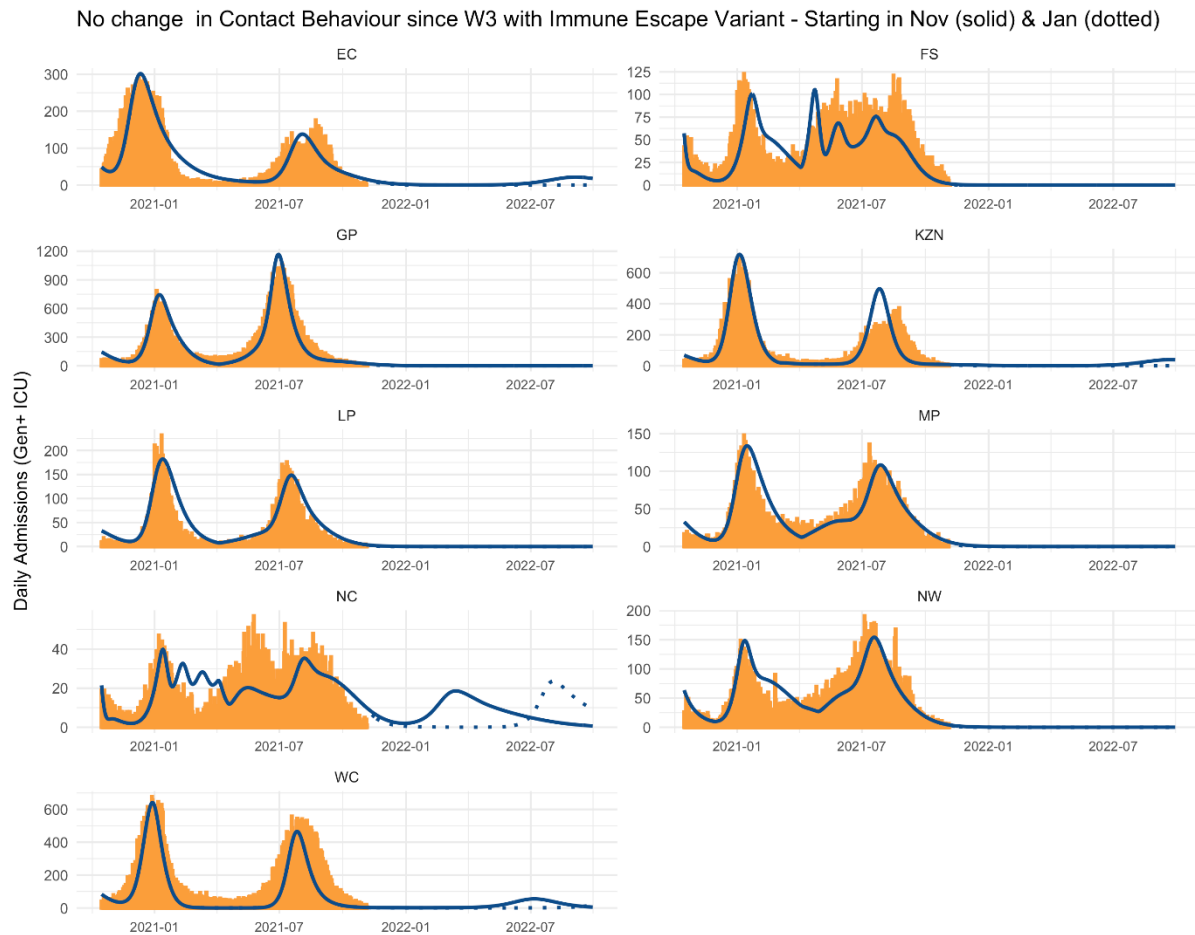

**Scenario 4: Behavioural response threshold increased (2x), immune escape variant present**

With its more realistic assumption of increasing contacts in the coming months, scenario 4 mirrors scenario 1, but with a new immune escape variant present. In this scenario, the fourth wave peak hospital admissions are still projected to be lower than those in waves 2 and 3 (Figure 6A). Note that in this scenario, the atypical trajectory of previous waves in both the Northern Cape and the Free State results in greater effect of the hypothetical new variant. As seen before, even in this scenario, the higher vaccination rates among those aged 60+ years reduces the projected severe cases and admissions, at least as long as vaccine protection against severe illness does not wane for the entire projection horizon (Figure 6B).

**Figure 6A: Fourth wave scenario 4: Impact on hospital admissions, by province (compared to 2<sup>nd</sup> and 3<sup>rd</sup> waves).** Orange bars represent admissions data from DATCOV/NICD; blue curves represent model fits/projections.

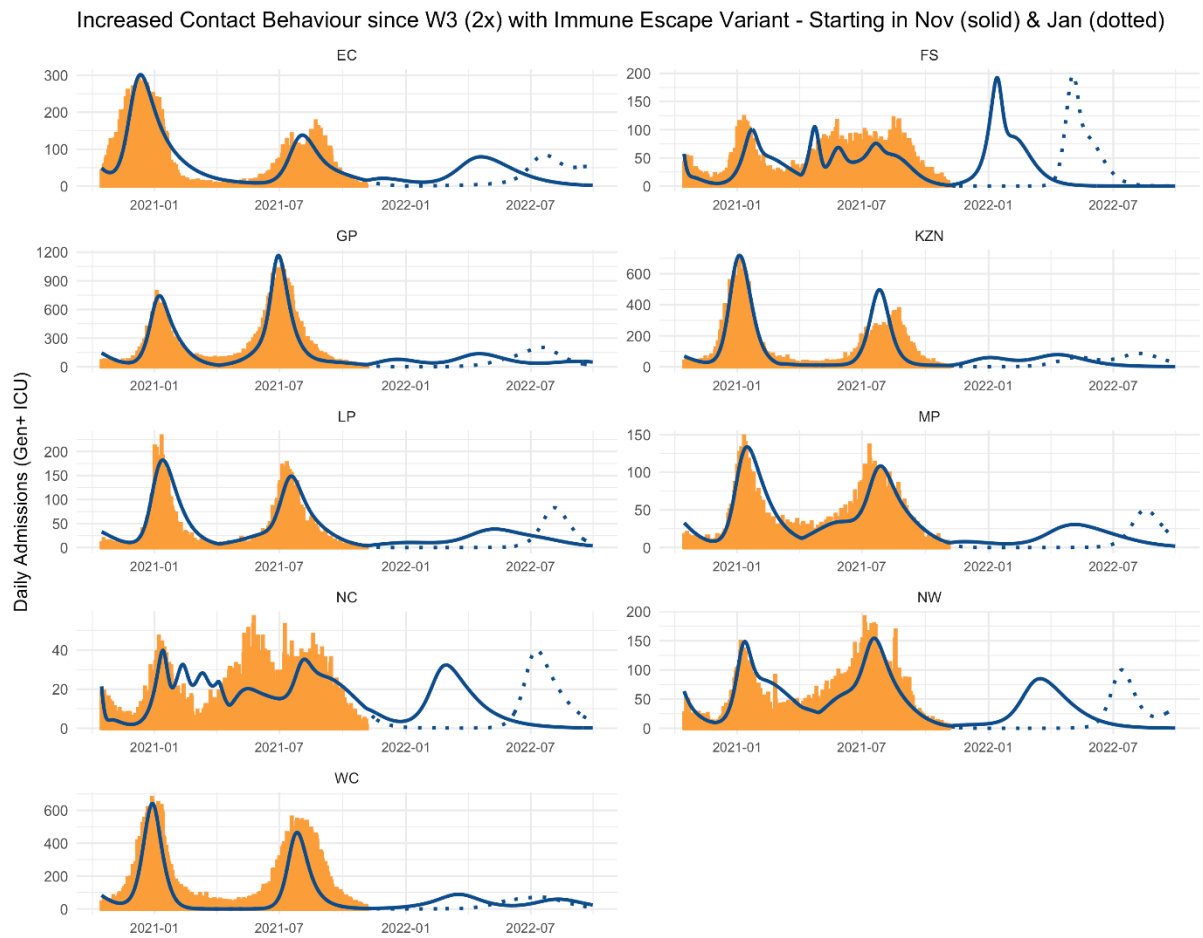

**Figure 6B: Fourth wave scenario 4: Impact on hospital admissions, by age group (compared to 2<sup>nd</sup> and 3<sup>rd</sup> waves).** Orange bars represent admissions data from DATCOV/NICD; blue curves represent model fits/projections

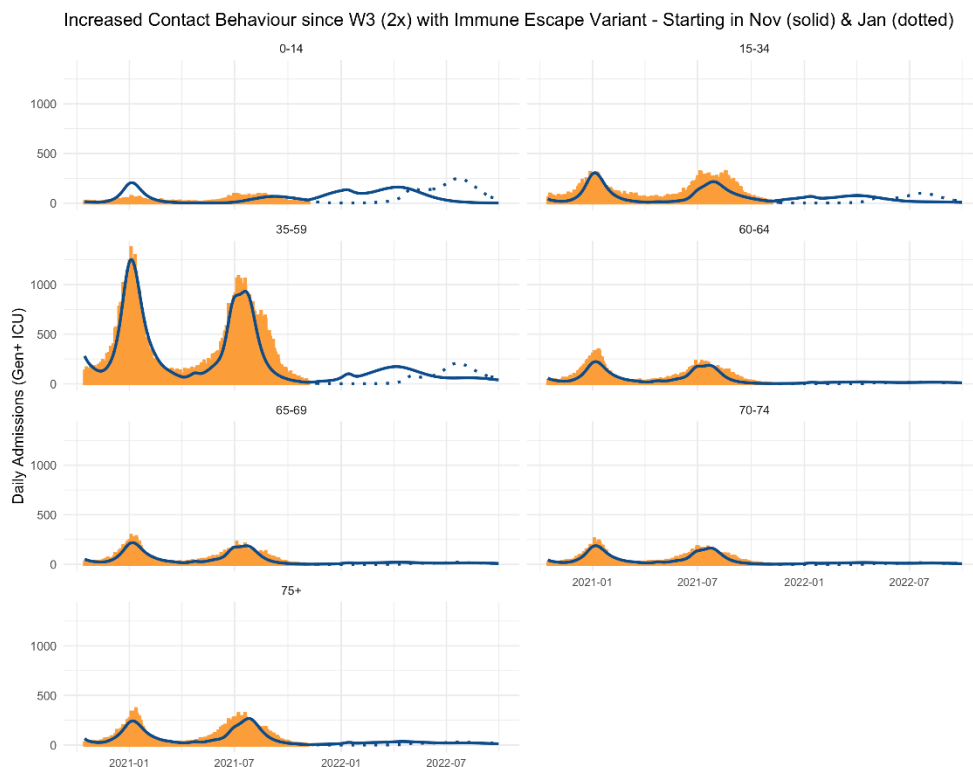

#### 4. Summary: Quantifying the impact of a fourth wave

Across all modelled scenarios, we estimated the impact of the fourth wave to be lower than the second or third wave in terms of hospital admissions and total deaths (Table 2). It is important however to note that other scenarios, for example one incorporating a new VOC with substantial increase in transmission, are possible. As can be seen, there is large variation between the four scenarios (Figure 7), emphasising the impact that individual behaviour and a potential new variant of concern with relevant immune escape properties can have on the size of the next wave (as well as its timing).

**Table 2: Impact of 1<sup>st</sup>, 2<sup>nd</sup> and 3<sup>rd</sup> waves on hospital admissions, hospital-based deaths, and total deaths, compared to two 4<sup>th</sup> wave scenarios (numbers rounded to the nearest 100)**

	Wave 1	Wave 2	Wave 3	Wave 4 <sup>#</sup>	
				Scenario 1	Scenario 4
Hospital admissions	103,400	150,000	177,500	20,200	86,700
All COVID-19 deaths (in and out of hospital)	39,300 <sup>+</sup>	80,300 <sup>+</sup>	93,000 <sup>+</sup>	8,200	44,800

<sup>#</sup> representing sub-scenarios with changes effected in January or November, whichever value was highest

<sup>+</sup> estimated as 85% of excess deaths<sup>9</sup>

<sup>9</sup> Correlation of Excess Natural Deaths With Other Measures of the Covid-19 Pandemic in South Africa. Burden of Disease Research Unit, South African Medical Research Council (23 February 2021). <https://www.samrc.ac.za/sites/default/files/files/2021-03-03/CorrelationExcessDeaths.pdf>

**Figure 7: Impact of a potential fourth wave on hospital admissions and total deaths, by scenario** (BR=behavioural response [“-”=no change, “+”= increase in contact rate “0”=removal of threshold]; Var = immune escape variant [“-”=not present, “+”=present])

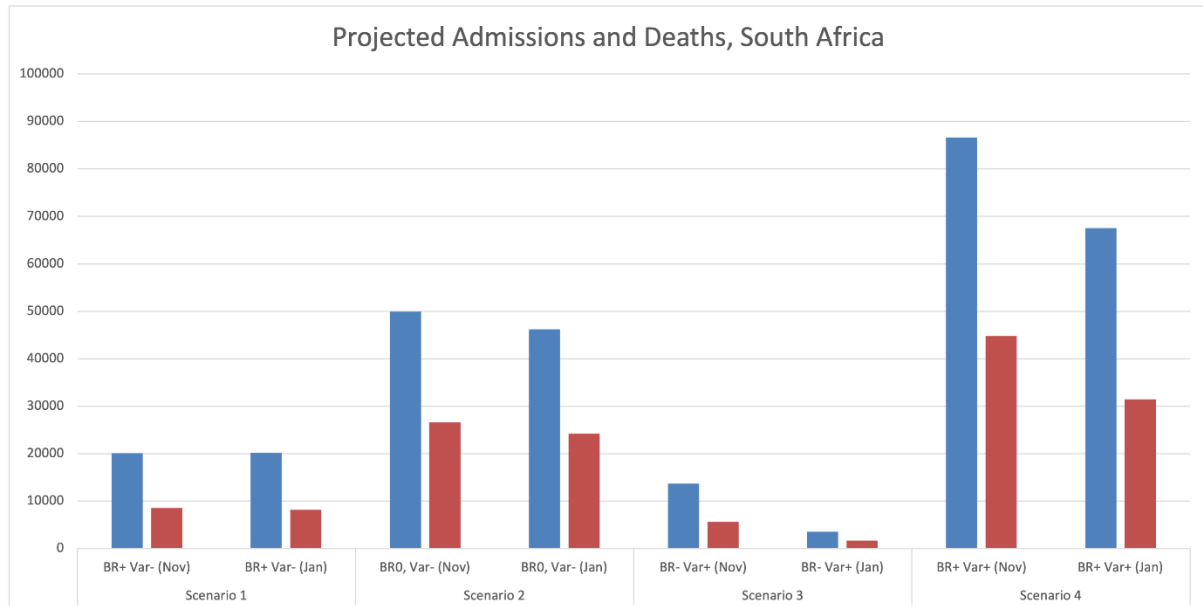

### **Waves of infections and admissions**

Across all modelled scenarios, the impact of changes in population behaviour and a hypothetical immune escape variant has been presented for hospital admissions and deaths. In these scenarios, total hospital admissions and deaths are projected to be lower than Waves 2 and 3; however, this is not necessarily true for infections in these scenarios. Vaccination, for example, is substantially more effective at preventing severe diseases than infection<sup>10</sup>. With high seroprevalence and vaccination coverage assumed to reach 70% by the end of March 2022, a given number of infections will translate into substantially reduced numbers of severe cases and admissions, relative to what was seen in previous waves. Thus, while admissions may be projected to be low, sizable waves of infections, and therefore detected cases, may still occur. In scenarios 1 and 4, while total admissions were projected to be one fifth (scenario 1) or half (scenario 4) of Wave 3, the waves of infections were considerable (Figure 8).

<sup>10</sup> Pouwels et al. Effect of Delta variant on viral burden and vaccine effectiveness against new SARS-CoV-2 infections in the UK. <https://www.nature.com/articles/s41591-021-01548-7>

Figure 8: Total infections during 3<sup>rd</sup> wave and two 4<sup>th</sup> wave scenarios, both with changes effected in November

(A) 4<sup>th</sup> wave scenario 1

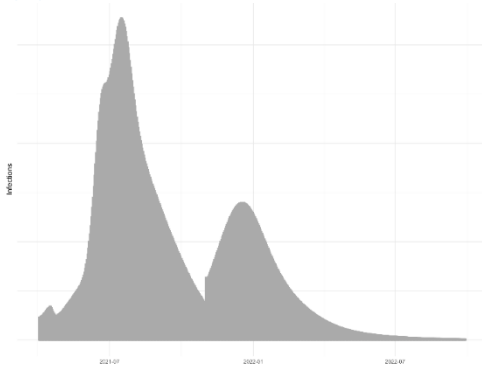

(B) 4<sup>th</sup> wave scenario 4

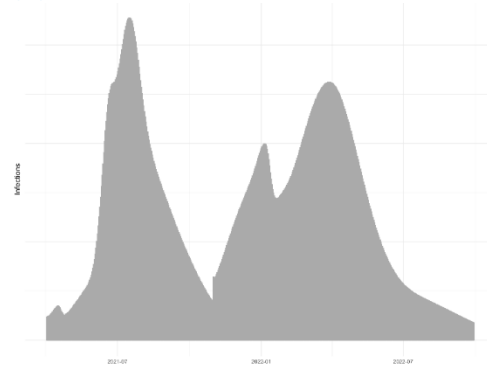

## 5.

### Contextualising the findings

It is important to consider our findings in the context of the following points:

- As in our third wave projections, seroprevalence data remain a key source of information to establish the basis for future projections. The remaining uncertainty in and low availability of these data however reduces the ability to produce robust projections in some of the provinces, in particular the Northern Cape and Free State.
- It might be of interest to note that the impact of the protective extent of previous infection is not unique to South Africa: Bauer et al. (2021)<sup>11</sup> showed, in a modelling study across European countries, that countries with higher seroprevalence at the start of vaccine rollout required lower vaccine coverage in order to avoid breaching ICU capacity.
- The model currently assumes the same vaccine effectiveness of the Pfizer and J&J vaccines against the Delta variant across all age groups, as there is insufficient reliable data to disaggregate this effectiveness into age categories. This assumption may be updated in future iterations of the model as data become available.
- The model currently assumes that vaccine effectiveness against severe disease does not wane in the projection period. Andrews et al. (2021)<sup>12</sup> showed limited waning in vaccine effectiveness against hospitalisation and death more than 20 weeks post-vaccination with Pfizer. Similar findings were reported by Tartof et al. (2021)<sup>13</sup>, Goldberg et al. (2021)<sup>14</sup> and Poukka et al. (2021)<sup>15</sup>. Future model updates will include waning protection against severe disease as additional data become available. However, the effect of waning may be limited in the South African setting. Many individuals with immunity derived from prior infection are likely to have been re-exposed during subsequent waves, and those vaccinated early in the

<sup>11</sup> Bauer S, et al. (2021) Relaxing restrictions at the pace of vaccination increases freedom and guards against further COVID-19 waves. PLOS Computational Biology 17(9): e1009288. <https://doi.org/10.1371/journal.pcbi.1009288>

<sup>12</sup> Andrews, et al. (2021) Vaccine effectiveness and duration of protection of Comirnaty, Vaxzevria and Spikevax against mild and severe COVID-19 in the UK. <https://www.medrxiv.org/content/10.1101/2021.09.15.21263583v1>

<sup>13</sup> Tartof, et al (2021) Effectiveness of mRNA BNT162b2 COVID-19 vaccine up to 6 months in a large integrated health system in the USA: a retrospective cohort study. [https://doi.org/10.1016/S0140-6736\(21\)02183-8](https://doi.org/10.1016/S0140-6736(21)02183-8)

<sup>14</sup> Goldberg, et al (2021) Waning Immunity after the BNT162b2 Vaccine in Israel. <https://www.nejm.org/doi/full/10.1056/NEJMoa2114228>

<sup>15</sup> Poukka et al (2021) Cohort study of Covid-19 vaccine effectiveness among healthcare workers in Finland, December 2020 - October 2021 <https://www.medrxiv.org/content/10.1101/2021.11.03.21265791v1>

roll-out may have been exposed in the third wave; such exposures would be expected to boost existing immunity.

- The peak and number of hospital admissions across the modelled scenarios have been compared to those observed in previous waves. While we conclude that admissions and deaths in the modelled scenarios are lower than those observed in Waves 2 and 3, this does not imply that hospital capacity will not be breached. In previous waves capacity was expanded in many hospitals through limiting elective surgeries, converting wards, increasing staff, and the establishment of bed bureaus and public-private partnerships. If these measures are limited or no longer in place, the capacity for hospitals to admit COVID-19 patients will also be limited and capacity may be breached at lower admissions levels than in previous waves. Therefore hospital and facilities' planners should interpret the model estimates of admissions in light of currently available hospital capacity and resources.
- In this analysis, we model the emergence of an immune escape variant with 25% relative reduction in protection conveyed through prior infection and vaccination, with loss of protection against hospitalisation in particular. Given that it is not possible to predict the timing of the emergence, or the likely characteristics, of a VOC, we considered which characteristics would be most valuable to model. In light of the already high transmissibility of the Delta variant and the high estimated seroprevalence in South Africa, with increasing vaccination, we chose to include a hypothetical immune escape variant without increased transmissibility. If a new variant emerges or enters circulation in South Africa, the model will be updated to reflect its characteristics.
- The model results presented in this report are scenario analyses rather than forecasts. Forecasts offer an estimate of the probable future trends (e.g., infections or admissions) within an uncertainty range and may be tested for accuracy retrospectively, comparing actual events (e.g., observed admissions) with forecasts of those data). Scenario modelling, on the other hand, is answering a set of "what-if" questions to evaluate the impact of changes to the system presenting multiple possible futures. In this analysis, we ask questions including "What if population contact behaviour increases in the coming months?", "What if a variant that results in immune escape enters circulation?". We have chosen this approach as population behaviour is difficult to measure and therefore predict, and it is not possible to predict the timing of the emergence, or the likely characteristics, of VOCs.
- The NCEM, as with all models, is a simplified representation of reality that is designed to describe and predict system behaviour. Model robustness is likely to be improved as more data becomes available.

## **6. A way forward to monitor resurgence**

The SACMC Epidemic Explorer is a dashboard built by the SACMC to explore the COVID-19 epidemic in South Africa, analysing current trends, presenting metrics to prepare for future resurgences, and monitoring COVID-19 hospital admissions ([www.SACMCEpidemic Explorer.co.za](http://www.SACMCEpidemicExplorer.co.za)). This open access dashboard presents a subset of the metrics used to support the planning efforts of the government of South Africa. The public can use it to assess the COVID-19 risk level in any district and sub-district in the country.

The dashboard currently presents case-based metrics to detect changes in the trajectory of cases that are linked to Control-Alert-Response thresholds to guide epidemic planning and response.

With increased vaccine coverage and the protection offered by vaccines against hospitalisation, the link between the trajectories of cases and admissions is expected to be weaker. Increases in cases will still lead to increases in admissions, but as demonstrated in the modelled scenarios, sizeable waves of cases may occur with a relatively low level of admissions. The SACMC is currently engaged in revising metrics that will be robust indicators of resurgence for a country with high seroprevalence and a growing vaccination programme, and the metrics displayed on the SACMC Epidemic Explorer dashboard might change as a result of that.



## Appendix

### **The National COVID-19 Epi Model (NCEM v6.0)**

The National COVID-19 Epi Model (NCEM) is an epidemiological model that was developed by the South African COVID-19 Modelling Consortium. Since being used to produce projections for the first wave of the South African epidemic in May 2020, the model has been adapted and updated several times as new data became available. The NCEM is a compartmental transmission model that estimates the total and reported incidence of COVID-19 cases, hospitalisations, and deaths in South Africa. In this version, the spatially-explicit model is calibrated to model the spread of infection in the 9 provinces of South Africa. The model follows a generalised Susceptible-Exposed-Infectious-Removed (SEIR) structure accounting for disease severity (asymptomatic, mild, severe and critical cases) and treatment pathways (outpatient services, inpatient non-ICU, and ICU beds). Version 6.0 has been updated to incorporate the Beta and Delta variants and additional features suitable to modelling vaccination, as well as a hypothetical new Variant of Concern with immune escape properties, specifically resulting in a loss of protection against infection and severe disease. Version 6.0 of the NCEM is a multi-strain, age-structured, spatially-explicit, generalised SEIR compartmental model of COVID-19 (Figure A1).

Figure A1: The National COVID-19 Epi Model v6.0

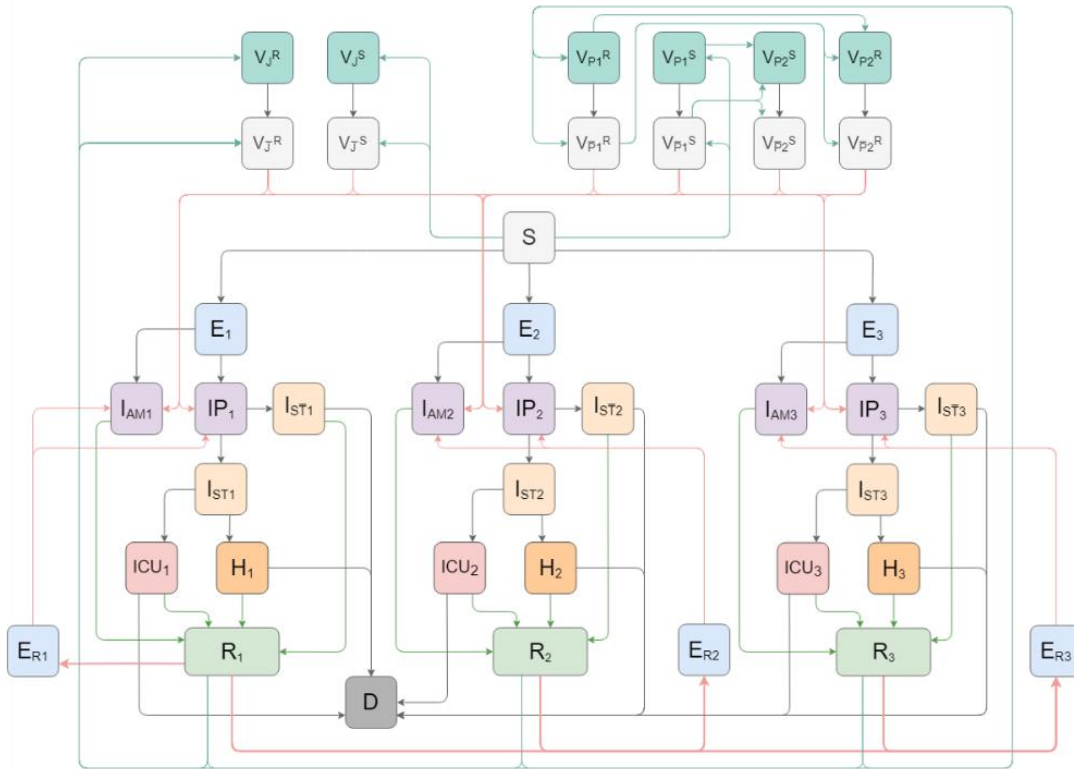

Model States

VACCINATION (J&J)	
$V_{jR}$	Vaccinated, from Recovered state, Protected
$V_{jS}$	Vaccinated, from Susceptible state, Protected
$V_{jR}$	Vaccinated, from Recovered state, Not protected
$V_{jS}$	Vaccinated, from Susceptible state, Not protected
VACCINATION (PFIZER)	
$V_{P1R}$	Vaccinated, from Recovered state, Dose 1, Protected
$V_{P1S}$	Vaccinated, from Susceptible state, Dose 1, Protected
$V_{P1R}$	Vaccinated, from Recovered state, Dose 1, Not protected
$V_{P1S}$	Vaccinated, from Susceptible state, Dose 1, Not protected
$V_{P2R}$	Vaccinated, from Recovered state, Dose 2, Protected
$V_{P2S}$	Vaccinated, from Susceptible state, Dose 2, Protected
$V_{P2R}$	Vaccinated, from Recovered state, Dose 2, Not protected
$V_{P2S}$	Vaccinated, from Susceptible state, Dose 2, Not protected
COVID-19 STATES	
S	Susceptible
E	Exposed (not infectious)
$E_R$	Exposed, re-infected (not infectious)
$I_{AM}$	Infected, asymptomatic or mild
$I_P$	Infected, pre-symptomatic
$I_{ST}$	Infected, severe, untreated
$I_{ST}$	Infected, severe, seeking treatment
H	Infected, severe, in general ward
ICU	Infected, critical, in ICU
R	Recovered
D	Died
SUBSCRIPTS	
1	Wild Type
2	Beta Variant
3	Delta Variant

Model Flows

ARROW COLOURS	
	Vaccination
	Infection
	Reinfection
	Recovery
	Death

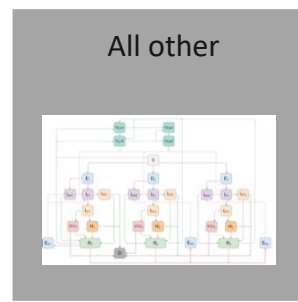
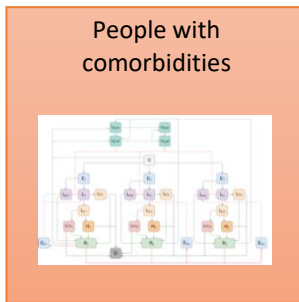

Model features added over the last months include:

- **Age structure:** The population has been subdivided into age classes accounting for age-related differences in susceptibility to and severity of COVID-19 and to allow for age-related disease characteristics and age-targeted vaccination.
- **Multi-strain:** The wild type SARS-CoV-2 infection and the Beta and Delta variants dominating transmission in South Africa's second and third wave of infections, respectively, have been incorporated. The structure assumes no co-infection with multiple strains, but allows for low levels of reinfection with other variants<sup>16</sup>. Likewise, imperfect natural immunity allows reinfection with the same lineage, with a lower transmissibility. The latest version additionally allows for a hypothetical new Variant of Concern with immune escape properties, reducing protection against infection and severe disease.
- **Vaccination:** The model has been developed to account for vaccination of the susceptible and naturally immune populations with multiple vaccines of 1 or 2 doses, allowing for age-targeting, vaccine waning, imperfect protection, and the ability to provide distinct levels of protection against infection and severe disease.
- **Priority populations:** Age-stratified priority populations are defined as Healthcare Workers, Population with Comorbidities, and Everyone Else with the ability for vaccine distribution to be tailored to these populations with respect to the type of vaccine, the timing of vaccination, and population age (Figure A1). The specific contact patterns and disease characteristics of these priority populations are also captured.

---

<sup>16</sup> Pulliam JR, van Schalwyk C, Govender N, von Gottberg A, Cohen C, Groome MJ, Dushoff J, Mlisana K, Moultrie H: SARS-CoV-2 reinfection trends in South Africa: analysis of routine surveillance data. Preprint available under <https://www.medrxiv.org/content/10.1101/2021.11.11.21266068v1>.

## About the South African COVID-19 Modelling Consortium

The South African COVID-19 Modelling Consortium is a group of researchers from academic, non-profit, and government institutions across South Africa. The group is coordinated by the National Institute for Communicable Diseases, on behalf of the National Department of Health. The mandate of the group is to provide, assess, and validate model projections to be used for planning purposes by the Government of South Africa. For more information, please contact Dr Harry Moultrie (harrym@nicd.ac.za).

## Acknowledgements

We thank staff at NICD, NHLS, SANBS, HSRC, WCDoH, SAPRIN, Minerals Council SA, NHLS, Wits VIDA, SAMRC and the Network for Genomic Surveillance South Africa (NGS-SA) for making seroprevalence and variant prevalence data available to us.

We also acknowledge the support of our funders (see below). MASHA was funded for this work by the Wellcome Trust (GN: 214236/Z/18Z). HE<sup>2</sup>RO was funded for this work by cooperative agreement AID-OAA-A-15-00070 with the United States Agency for International Development (USAID). The funders had no role in study design, data collection and analysis, decision to publish or preparation of the report. The author's views expressed in this publication do not necessarily reflect the views of the United States Agency for International Development or the United States Government. SACEMA is supported by the Department of Science and Innovation and the National Research Foundation. Any opinion, finding, and conclusion or recommendation expressed in this material is that of the authors, and the NRF does not accept any liability in this regard. The SACMC additionally received support from the Bill & Melinda Gates Foundation under Investment 035464. The findings and conclusions contained within are those of the authors and do not necessarily reflect positions or policies of the Bill & Melinda Gates Foundation.

### MASHA



GN: 214236/Z/18Z

### HE<sup>2</sup>RO



### SACEMA

